

CHUKA



UNIVERSITY

UNIVERSITY EXAMINATIONS

EXAMINATION FOR THE AWARD OF DIPLOMA IN COMPUTER

PHYS 0101/0111: PRINCIPLES OF PHYSICS

STREAMS: DIP (COMP SCI)

TIME: 2 HOURS

DAY/DATE: THURSDAY 08/07/2021

8.30 A.M. – 10.30 A.M.

INSTRUCTIONS:

- Answer question one and any other two questions.

Question One

- Define the following terms
 - Vector quantity (1 mark)
 - Scalar quantity (1 mark)
 - Physical quantities (1 mark)
 - System of units (1 mark)
- Give two supplementary quantities stating the respective units (4 marks)
- State the two types of errors in measurements (2 marks)
- Explain how to minimize the errors above (2 marks)
- A truck of mass 2,000 kg starts from rest on horizontal rails. Find the speed 3 seconds after starting if the tractive force by the engine is 1,000 N. (4 marks)
- A bullet of mass 10g is shot into water melon of mass 0.2kg which is resting on a platform. At the time of impact, the bullet is travelling horizontally at 20ms^{-1} . Calculate the common velocity after impact (3 marks)
- A ray of light travelling through a liquid of absolute refractive index 1.4 is incident on the plane surface of a Perspex block at an angle of 55° . Calculate the angle of refraction in

- the Perspex if it has an absolute refractive index 1.5 (4 marks)
- h. state two conditions for total internal reflection to take place. (2 marks)
- i. An object is placed 10cm in front of a concave mirror of radius of curvature 15 cm. Find the position, nature, and magnification of the image in each case.(3 marks)
- j. List two applications of magnetic effect of electric current. (2 marks)

Question Two

- a. State the three Newton's laws of motion giving the equations governing them(3 marks)
- b. Derive the Newton's second equation of motion. (4 marks)
- c. A wooden box of mass 30 kg rests on a rough floor. The coefficient of friction between the floor and the box is 0.6.Calculate
- i. The force required to just move the box (2 marks)
 - ii. If a force of 200 N is applied the box with what acceleration will it move? (2 marks)
- d. Differentiate between elastic and in elastic collisions (4 marks)
- e. Find the distance traveled by a car in the 7th second if it has an initial velocity of 10m/s and accelerating at the rate of 3m/sec^2 (5 marks)

Question Three

- a. Give the three equations of linear motion (3 marks)
- b. Given that the velocity of a particle is $V = m + nt^2$ where $m = 10\text{cm s}^{-1}$ and $n = 2\text{cms}^{-1}$
- i. Find the change in velocity of the particle in the time interval between $t_1 = 2\text{s}$ and $t_2 = 5\text{s}$.(3marks)
 - ii. Find the average acceleration in this time interval. (2 marks)
 - iii. Find the instantaneous acceleration at time $t_1=2\text{s}$ (2 marks)
- c. A car starts from rest and accelerates at 10m/s^2 in 20 seconds. Find the final velocity of this car (3 marks)
- d. A boy rolls a ball along a flat straight platform. The ball possesses an initial velocity of 2ms^{-1} when the boy releases it and it shown down with a constant negative acceleration of -2m s^{-2} . How far does the ball roll before stopping, and how long does

it take to stop? (4 marks)

- e. The mass of the moon is about one eighty-first, and its radius one fourth, that of the earth. What is the acceleration due to gravity on the surface of the moon? (3 marks)

Question Four

(a)

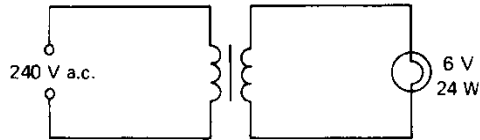

It is required to run a 6-V, 24-W lamp from 240-V a.c. mains using a transformer as shown above.

- (i) Calculate the current that would be taken by the lamp when operating normally. (2 marks)
 - (ii) Calculate the turns ratio of the transformer you would use. (2 marks)
 - (iii) Calculate the current taken by the primary coil of the transformer, assuming it to be 100% efficient. (2 marks)
 - (iv) Why, in practice, is the efficiency of the transformer less than 100%?(3 marks)
- (b) State three factors that affect the resistance of a metallic conductor. (3 marks)
- (c) Four resistors are arranged as shown below

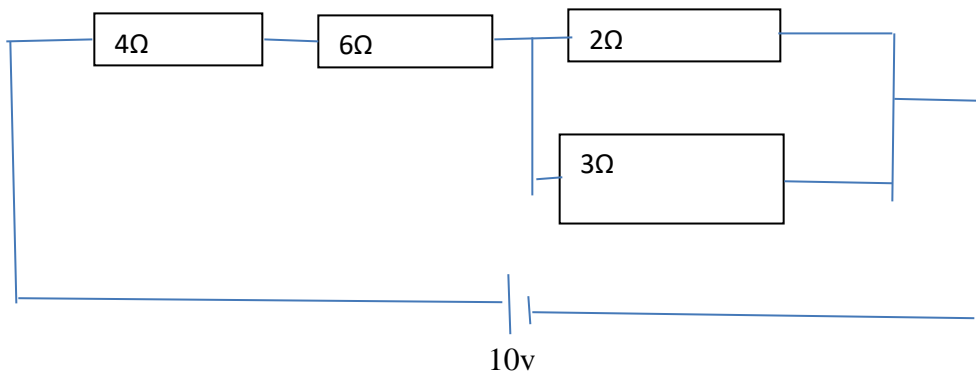

Calculate:

- (i) The effective resistance (4 marks)
- (ii) calculate the potential difference across each resistor (4 marks)

Question Five

1. a) i) Define the following terms

Principle focus

Focal length

(2 marks)

ii) Show that image formed by a plane mirror is as far behind the mirror as the object is in front.

(6 marks)

b) An object is placed 20 cm from a concave mirror of focal length 15 cm, show using ray construction the location of the image, describe the characteristics of the image (6 marks)

By applying mirror formula, find the position of an object that gives an image located 15 cm in front of a concave mirror of focal length 10cm. (6 marks)

.....