

CHUKA



UNIVERSITY

**UNIVERSITY EXAMINATIONS**

**FOURTH YEAR EXAMINATION FOR THE AWARD OF DEGREE OF BACHELOR OF SCIENCE (GENERAL) AND BACHELOR OF EDUCATION (SCIENCE)**

**PHYS 419: COMMUNICATION ELECTRONICS II**

**STREAMS: B.Sc. (GENERAL) & B.ED (SCIENCE) Y4S1**

**TIME: 2 HOURS**

**DAY/DATE: TUESDAY 11/12/2018**

**8.30 A.M. – 10.30 A.M.**

---

**INSTRUCTIONS:**

- **Answer Question ONE and ANY Other TWO Questions.**

**Question One (30 marks)**

(a) Explain why a signal is modulated before transmitting (3marks)

(b) NTV station uses FSK carrier signal with mark and space frequencies of 99.6 MHz and 101.2 MHz respectively. Determine for the transmitting carrier signal;

- (i) The peak frequency deviation (3marks)
- (ii) Minimum bandwidth (2marks)
- (iii) Baud for binary FSK signal (2marks)

(c) Discuss the three type of digital modulation (6marks)

(d) With the aid of a well labeled block diagram, describe a simple transmitter of a communication system. (5marks)

(e) What are the functions of the following elements in a receiver circuit?

- (i) BPF (4marks)
- (ii) ADC (2marks)
- (iii) LPF
- (iv) Antenna

(f) Differentiate between analogue and digital modulation (2marks)

(g) Define the term modulation and give two examples of digital modulation (3marks)

**Question Two (20 marks)**

(a) Citizen TV station uses an ac carrier signal with a voltage given by the relation;

$$y = 300 \sin(3 \times 10^{14}t + \pi/2)$$

Determine for the transmitting carrier signal;

- (i) Peak voltage (2marks)
- (ii) Frequency of transmission (3marks)
- (iii) Phase angle (2marks)

(b) Discuss the three type of analogue modulation (9marks)

(c) Discuss the TE and TM modes of wave propagation (4marks)

**Question Three (20 marks)**

(a) With the aid of a well labeled block diagram, describe the elements of a communication system. (12marks)

(b) Differentiate between carrier and message signal.(2marks)

(c) What are the functions of limiters in a communication system? (5marks)

**Question Four (20 marks)**

(a) The circuit in figure 4.1 is an example of a one transistor, low power CW transmitter. Describe briefly, how it operates. (10marks)

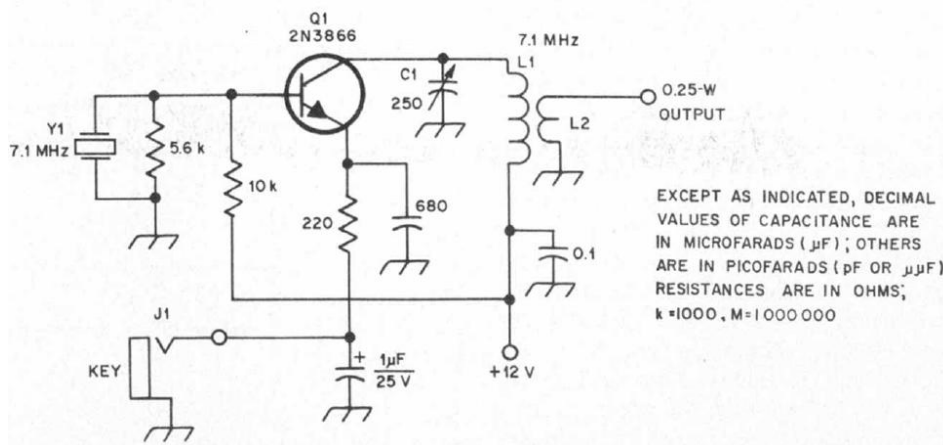

**Figure 4.1.** A one transistor low power CW transmitter.

(b) Discuss the basic electronics implemented to achieve sharing the communication channel through frequency division. (5marks)

(c) Explain the work of discriminators in a communication system. (5marks)

**Question Five (20 marks)**

(a) Cross over distortion is usually observed in transistor amplifiers. Describe this phenomenon and explain how it affects audio signal in a receiver. (10marks)

(b) Figure 5.1 is a block diagram of quadrature demodulator. Discuss how it works while highlighting baseband and bandpass models. (10marks)

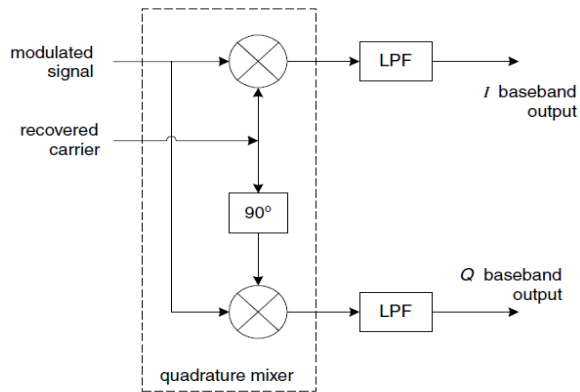

**Figure 5.1.** Quadrature demodulator.