

CHUKA

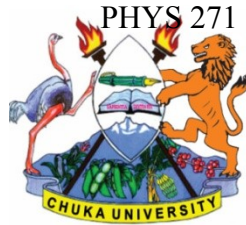

UNIVERSITY

UNIVERSITY EXAMINATIONS

SECOND YEAR EXAMINATION FOR THE AWARD OF DEGREE OF BACHELOR OF SCIENCE (PHYSICS) AND BACHELOR OF EDUCATION (SCIENCE)

PHYS 271: BASIC ELECTRONICS

STREAMS: B.Sc (PHYSICS,CHEM,MATHS), B.Ed (Sc); Y2S2: TIME: 2 HOURS

DATE: FRIDAY 12/04/2019

11.30 A.M – 1.30 P.M

INSTRUCTIONS:

Answer question one and any other two questions

Useful constant: $q = 1.62 \times 10^{-19} \text{ C}$

Question One (30 marks)

- (a) Define the following terms as used in physics of semiconductors
- (i) Recombination (1mark)
 - (ii) Donor atoms (1mark)
- (b) Explain why the base of a BJT transistor is lightly doped and thin as compared to emitter and the collector (2marks)
- (c) Describe the behavior of depletion layer of a pn junction diode when reversed biased. (3marks)
- (d) Describe how n-type and p-type semiconductors are formed (4marks)
- (e) Sketch the circuit diagram showing how the p-n junction diode is;
- (i) Forward biased and why it conduct current in this mode (2marks)
 - (ii) Reversed biased and why it doesn't conduct current in this mode (2marks)
- (f) Sketch the I-V characteristics of a forward biased p-n junction diode (2marks)
- (g) Describe briefly at least three scattering techniques in semiconductor crystals (3mark)
- (h) A sample of silicon was doped with 10^{17} acceptor atoms/cm³. Determine its resistivity if hole mobility = 700 cm²/Vs (3marks)
- (i) Organic semiconductors are attracting the interest of researchers than inorganic semiconductors, why? (2marks)

- (j) What is the important of feedback in transistor amplifiers (1mark)
- (k) Sketch the output transfer (I-V) characteristics of a BJT transistor (3marks)
- (l) Explain how light emitting diode (LED) operate (1mark)

Question two (20 marks)

- (a) With a well labeled circuit diagram, explain how a bridge rectifier works. Sketch its output when connected to a C.R.O with and without the capacitor across the load (6marks)
- (b) Describe the Hall effect phenomenon with a well labeled Hall effect experimental set up (6marks)
- (c) A student designed a project using a pn junction diode D as shown in figure 2.1 to control the lighting of an LED.

- (i) What is the function of resistor R in this circuit (2marks)

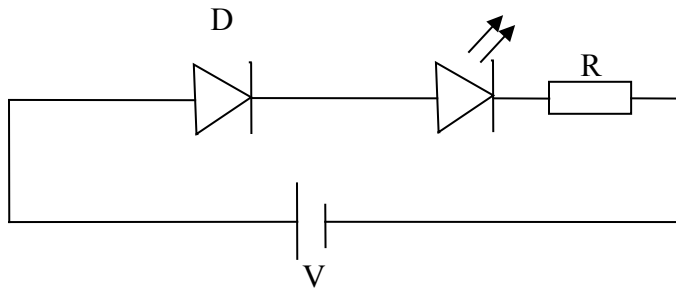

Figure 2.1. Transistor amplifier circuit.

- (ii) With the correct value of R, explain whether the LED will light or not when the circuit is connected (3marks)
- (iii) Given a photodiode, how can you modify the circuit to function as a security system in case someone comes closer to the main door of a house (3marks)

Question three (20 marks)

(a) A researcher in Chuka University Physics laboratory was using Hall apparatus to study the properties of germanium thin film semiconductor. What information is likely to be obtained about this film (4 marks)

(b) In (3a), what Hall voltage would you expect to measure in a sample 1 m thick given;
 $I = 1 \text{ mA}$, $B_z = 10^{-5} \text{ W/cm}^2$ (3 marks)

(c) The transistor circuit in figure 3.1 acts as a simple voltage amplifier. If $R_C = 100 \text{ k}\Omega$ and $R_E = 10 \text{ k}\Omega$, $V_{CC} = 15 \text{ V}$, $V_B = 5 \text{ V}$, $\beta = 200$ and the transistor is made of silicon ie $V_{BE} = 0.7 \text{ V}$.

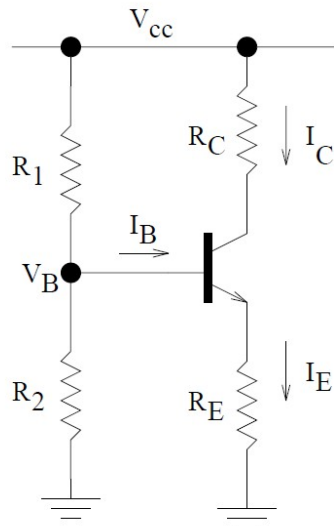

Figure 3.1. Transistor amplifier circuit.

- (i) Calculate I_C , I_E and V_E (7marks)
- (ii) What is the purpose of resistors R_1 and R_2 in the circuit (2marks)
- (iii) Apart from amplifiers, discuss other two applications of BJT transistors (2marks)

(d) Explain how the charge carriers (holes and electrons) flow in an intrinsic semiconductor (2marks)

Question four (20 marks)

(a) An n-p-n transistor circuit is given in figure 1 with $\beta = 100$ and the transistor is made of silicon ie $V_{BE} = 0.7 \text{ V}$.

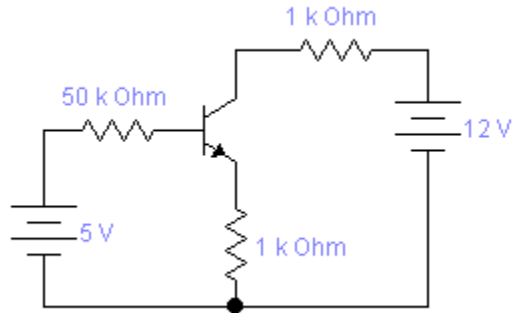

Figure 4.1. n-p-n transistor circuit.

Compute the following parameters for the given transistor

- (i) I_B (4mks)
- (ii) I_C (2mks)
- (iii) I_E (2mks)
- (iv) V_{CE} (3mks)

(b) With a well labeled diagram, describe how the following diodes operate: Shotky diode, Zener diode and tunnel diode (6marks)

(c) Explain why intrinsic semiconductor doesn't conduct electricity at room temperature

(3marks)

Question five (20 marks)

(a) Figure 5.1 shows a two stage current amplifier used in a sensor circuit with BJT transistors Tr_1 and Tr_2 .

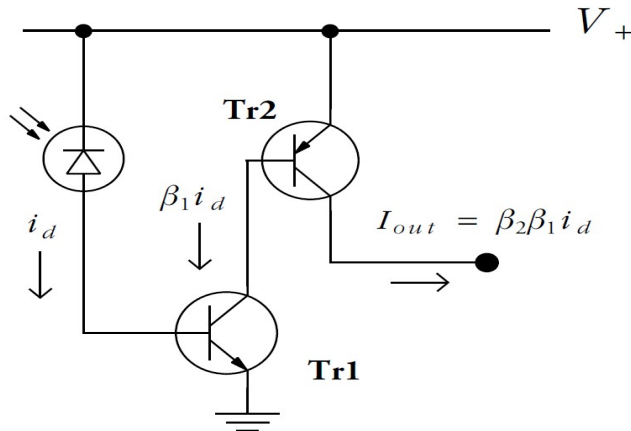

Figure 5.1. A two stage current amplifier based on BJT transistors.

- (i) Briefly explain how the current i_d is generated in the circuit when light falls on the given diode as shown. (3marks)
 - (ii) What is the purpose of V_+ voltage connected to the transistor Tr_2 and the diode. (2marks).
 - (iii) Given $\beta_1 = 200$ and $\beta_2 = 100$, calculate the gain of the two stage current amplifier (4marks)
 - (iv) Describe one practical application of the above circuit in security surveillance with slight addition of electronics components if any (3marks)
- (b) With a well labeled diagram, how is JFET different from BJTs from the design point of view. (6marks)
- (c) How is the resistance of the semiconductor material as compared to that of a metal . (2marks)

